

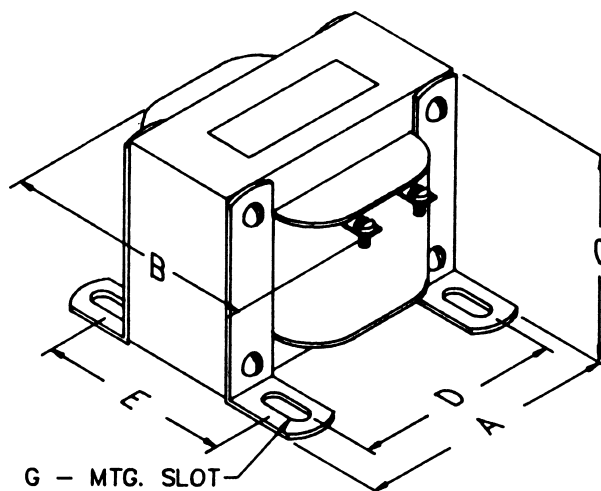

HEAVY CURRENT REACTORS



Chokes

- Open core & coil, 4-slot bracket mounting chokes.
- Tolerance of 15% on both inductance & resistance.
- Inductances measured at rated D.C. current.
- Connections are made to a screw terminal or heavy copper tabs with holes
- Perfect for high current power supply filtering.
- Working voltage 600 VAC typical
- Hi-Pot test at 2,000 VAC RMS

Selection Table

Cat. No.	Inductance Millihenries	Current D.C. Amps	Resistance Ohms	Insulation Class	Dimensions					Slot (G)	Wt. Lbs.
					A	B*	C	D	E		
195B150	0.5	150	.0018	B	5.25	5.50	4.47	4.38	4.13	.28 x .56	26
195C20	1.0	20	.013	A	3.00	3.06	2.50	2.50	2.25	.20 x .38	3
195C30	1.0	30	.009	A	3.75	3.85	3.13	3.13	2.50	.20 x .38	6
195C50	1.0	50	.005	A	4.50	5.25	3.75	3.75	3.50	.20 x .38	14.5
195C75	1.0	75	.004	A	5.25	6.00	4.47	4.38	4.63	.28 x .56	23
195C100	1.0	100	.0036	B	5.25	6.50	4.47	4.38	5.13	.28 x .56	26
195E20	2.5	20	.022	A	3.75	4.20	3.13	3.13	2.75	.20 x .38	6.5
195E30	2.5	30	.013	A	4.50	5.25	3.75	3.75	3.50	.20 x .38	12.5
195E50	2.5	50	.008	A	5.25	6.00	4.47	4.38	4.63	.28 x .56	23.5
195E75	2.5	75	.008	B	6.00	6.63	5.16	5.00	4.88	.28 x .56	32.5
195E100	2.5	100	.006	B	9.00	9.75	7.50	7.00	6.00	.44 x .75	75
195G10	5	10	.040	A	3.75	3.60	3.13	3.13	2.25	.20 x .38	5.5
195G20	5	20	.025	A	4.50	4.75	3.75	3.75	3.00	.20 x .38	10.5
195G30	5	30	.023	A	5.25	5.00	4.47	4.38	3.63	.28 x .56	16
195G50	5	50	.021	B	7.50	6.50	6.25	6.00	4.50	.38 x .63	38
195G75	5	75	.01	B	9.00	9.75	7.00	7.00	6.75	.44 x .75	87
195J10	10	10	.07	A	3.75	4.35	3.13	3.13	3.00	.20 x .38	8
195J20	10	20	.045	A	5.25	5.00	4.47	4.38	3.63	.28 x .56	17.5
195J30	10	30	.037	A	6.00	7.50	5.00	5.00	5.88	.31 x .50	36
195J50	10	50	.023	B	9.00	9.75	7.50	7.00	6.25	.44 x .75	79
195M10	20	10	.013	A	4.50	4.75	3.75	3.75	3.00	.20 x .38	10.2
195M20	20	20	.075	A	6.00	7.50	5.00	5.00	5.88	.31 x .50	34
195M30	20	30	.045	B	6.00	7.63	5.16	5.00	5.88	.28 x .56	41
195P5	30	5	.23	A	3.75	4.20	3.13	3.13	2.75	.20 x .38	6.5
195P10	30	10	.17	A	4.50	5.25	3.75	3.75	3.50	.20 x .38	16
195P20	30	20	.13	B	5.25	6.91	4.47	4.38	5.54	.28 x .56	28
195R10	50	10	.165	A	5.25	5.50	4.47	4.38	4.13	.28 x .56	26
195R20	50	20	.13	B	9.00	8.25	7.50	7.00	5.75	.44 x .75	72
195T5	100	5	.64	A	4.50	5.25	3.75	3.75	3.50	.20 x .38	14
195T10	100	10	.42	B	7.50	6.00	6.25	6.00	4.25	.38 x .63	35

* B dimension is approximate maximum over coil or copper tabs